Adamation

EG-2 / ARR-200

OPERATION,
MAINTENANCE
AND REPAIR
INSTRUCTIONS

ADAMATION, INC.
P.O. Box 37
87 Adams Street
Newton, MA 02195
PRINTED IN U.S.A.

PART NUMBER: 99-9000-011
Price: \$7.50
Revised December 1987

WARRANTY

Your Adamation Rotary Burnisher is guaranteed for one. Within twelve months of the date it is put into operation we will repair any defect in materials or workmanship. Adamation normally ships warranty parts via ground shipment from its factory in Newton, MA with Adamation assuming the ground shipment charges. If the customer elects to utilize an express method of shipping, then the customer shall pay the difference in cost between express shipping charges and ground shipping charges. Guarantee service may be obtained by contacting the Adamation National Service Department. Toll free phone 800-225-3075.

Because Adamation has no control over the quality, quantity and timeliness of the compounds supplied to the machine or over the methods of operation, the following items are not covered by this guarantee:

1. Burnishing balls that become rusty or discolored.
2. Cost of cleaning.
3. Damage caused by unreasonable neglect and carelessness in operation.

Replacement parts are guaranteed for ninety days or for the remainder of the guarantee, whichever is longer.

TABLE OF CONTENTS

WARRANTY.....	Page 1
SECTION 1 INTRODUCTION	
Machine Description.....	Page 3
Machine Specifications.....	Page 3
Basic Functioning.....	Page 3
SECTION 2 INSTALLATION	
Packaging Information.....	Page 4
Machine Assembly.....	Page 4
Preparing For Operation.....	Page 4
SECTION 3 OPERATION	
General.....	Page 4
Control Switch.....	Page 4
Opening The Burnishing Drum.....	Page 5
Fill Procedure.....	Page 6
Changing The Burnishing Solution.....	Page 6
Silverware Processing.....	Page 8
SECTION 4 THEORY OF BURNISHING	
The Burnishing Process.....	Page 8
How The Rotary Burnisher Works.....	Page 9
SECTION 5 MAINTENANCE	
General.....	Page 10
Preventive Maintenance.....	Page 10
Cleaning The Burnishing Balls.....	Page 11
Rust On The Burnishing Balls.....	Page 12
SECTION 6 ILLUSTRATED PARTS LIST	
General.....	Page 12
Ordering Information.....	Page 12-14

SECTION 1 INTRODUCTION

This manual contains information for installation, operation, and maintenance of the model EG-2 Burnisher. The theory of burnishing is also explained. Each replaceable part is identified in a parts list with reference to exploded views showing the locations of each.

MACHINE DESCRIPTION

The model EG-2 Burnisher is a highly mobile device for use in burnishing silver and silver plated flatware and hollow-ware. The machine consists of three sections: a rotary burnishing drum, a mounting frame with casters and a drive and belt guard assembly.

BURNISHING DRUM

The machine is equipped with a rotary burnishing drum having inside dimensions of 9 1/2 inches by 19 1/4 inches, accommodating 200 pieces of flatware in a single loading. A complete supply of 75 lbs. of 1/4-inch diameter steel burnishing balls are included. Rapid loading and unloading is provided by a removable cover fastened by means of four quick-acting lever latches.

MOUNTING FRAME

A mounting frame of stainless steel construction provides for support of the burnishing drum and alignment of the driving parts. Four casters allow for ease of mobility. Brakes on two of the casters provide for stability during operation.

DRIVE AND BELT GUARD ASSEMBLIES

A stainless steel motor cover and belt guard enclose the drive assembly. Operator protection is supplied by adjustment of the drive belt tension by means of an easily accessible adjusting bolt located below the base plate. Should the drum rotation become obstructed by accidental jamming, the drive is momentarily disengaged by slippage of the belt.

BASIC FUNCTIONING

The burnishing function is accomplished in the rotating burnishing drum loaded with 1/4-inch-diameter steel balls. Silverware is burnished by contact with the moving balls. A detailed explanation of the theory of burnishing is presented in Section 4.

SECTION 2 INSTALLATION

PACKAGING INFORMATION

The model EG-2 Burnisher is shipped in a single reinforced fiberboard carton complete with 75 lbs of burnishing balls. Also contained inside the drum are a set of fill and drain hoses and a one-gallon container of EG Burnishing Liquid. A carton containing the burnishing balls is loaded into the bottom of the crate.

The one-gallon container of EG Burnishing Liquid supplied with the machine is sufficient for initial operation of the Burnisher. Extra liquid for subsequent use is available as an additional item, shipped in individual cartons of four one-gallon containers. For ordering information see Section 6, Illustrated Parts List.

MACHINE ASSEMBLY

The machine is completely assembled for operation when removed from the carton, with the exception that the burnishing balls are not loaded into the drum. See Section 3 for instructions on how to open the burnishing drum. With the drum cover removed, the one-gallon container of EG Burnishing Liquid, the set of drain and fill hoses and the "Service Information" envelope are unpacked from the drum. The drum is then loaded with the 75 lbs of 1/4-inch-diameter burnishing balls.

PREPARING FOR OPERATION

Because this Burnisher is a mobile unit, installation is completed by rolling it on built-in casters to a convenient work area. The location selected must provide access to an electric wall outlet providing service as specified on the machine identification plate. Standard domestic machines require 120-volt, 60-cycle, grounded service. The machine is equipped with an eight-foot-long power cord. Close proximity to a house water supply connection is required for changing of the burnishing solution utilizing the drain and fill hoses supplied.

NOTE:

Some localities require that a syphon breaker be installed between the house water supply and the fill hose connection. Consult local plumbing codes for regional requirements.

The water source must allow for screw-on attachment of the fill hose, while any floor drain is sufficient for removal of the spent solution from the drain hose.

SECTION 3 OPERATION

GENERAL

Consult this section before attempting initial operation and as a subsequent guide to the use of the Burnisher. For initial operation, first complete the procedures contained in Section 2, Installation.

CONTROL SWITCH "OFF"

Make sure that the control switch located on the motor housing is in the "OFF" position. Plug the power cord into any wall outlet providing the correct voltage as specified on the machine identification plate. (Standard domestic machines require 120-volt, 60-cycle, grounded service.)

CAUTION:

Before operating the machine be sure that the drum cover is sealed in place with the latches in the locked (down) position. Loss of the burnishing balls can result from failure to seal the drum correctly.

CONTROL SWITCH

The standard model is equipped with a control switch. Placing this switch in the "ON" position will begin rotation of the burnishing drum. Rotation of the drum continues until the switch is returned to the "OFF" position.

OPENING THE BURNISHING DRUM

The cover must be at the top position before opening. With the power connected, positioning of the cover is easily accomplished by momentarily starting and stopping the machine until the cover is located at the top. Final adjustments can be made by twisting the drum by hand.

WARNING:

Operation of the Burnisher results in pressurization of the burnishing drum. To prevent splashing of the operator with compound solution, release this pressure slowly by first loosening one of the drain caps or by releasing latches on the side of the cover which is away from the operator.

To open the drum, the cover is released from the sealed position by lifting upward on the red handled latches. The cover is disengaged from the latches by sliding it off the end of the drum away from the belt guard, until the slotted end tabs have cleared the latch posts. See Figure 1 showing self-locking latch and cover operation.

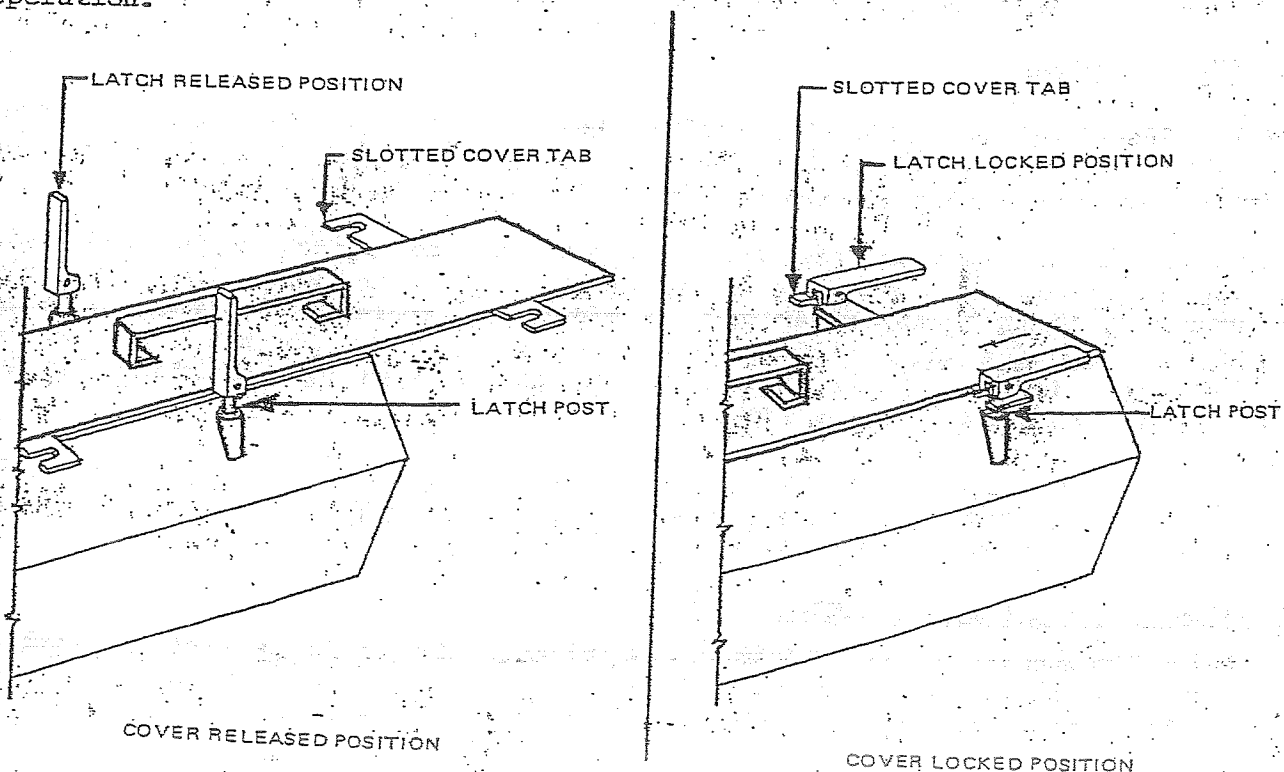

FILL PROCEDURE

Proper operation of the Burnisher requires that care be exercised in filling the burnishing drum. The procedure for filling includes preparation of the burnishing solution and loading of silverware to be burnished.

PREPARING THE BURNISHING SOLUTION

Preparation of the solution for burnishing is accomplished in the drum.

1. Add cold tap water to the burnishing balls in the drum until the water level above the balls reaches a depth of one inch. This amount of water is automatically established through use of the drain and fill hoses supplied. See Figure 2 for details.

2. Add four ounces of EG Rotary Burnishing Liquid, Adamation part number 65-7400-506. Local water conditions will cause the required amount to vary slightly.

It is not necessary to mix the liquid before loading the drum for burnishing. If burnishing is not to be completed immediately, it is necessary to mix the liquid as a means of protecting the burnishing balls from corrosion. Mix the liquid by operating the machine for 5 minutes.

LOADING PIECES TO BE BURNISHED

Flatware or hollow-ware of silver, silver plate, or stainless steel is loaded into the burnishing drum. Maximum recommended capacity for flatware is 200 pieces. The capacity for hollow-ware depends upon the size of the pieces.

CAUTION:

Never attempt to load for burnishing any pieces of aluminum, pewter, or similar metals. Never load for burnishing any silver, silver plate, or stainless steel which has not been cleaned of tarnish and food soil and thoroughly rinsed. Metal compounds and soil put into the solution not only reduce the solution's life but also cause the balls to become covered with a coating which inhibits burnishing.

MACHINE OPERATION

Before operating the burnisher, always check to be sure that the drum cover is securely fastened, as shown in Figure 1. The latch handles must be in the locked (down) position without protruding beyond the ends of the burnishing drum.

Standing clear of the burnishing drum, place the control switch in the "ON" position. Silver and silver plate which is burnished on a regular schedule may be sufficiently burnished to renew luster after only 15 minutes of operation. Silverware in poorly burnished condition will require more time. As much as six hours may be needed for removing deep scratches. Silverware is not damaged by burnishing for longer periods than required to renew luster.

Stainless steel requires longer operating time than silver. First inspection of stainless can be made after 1 1/2 hours of operation. Eight or more hours of operation may be required to renew deeply scratched stainless steel.

CHANGING THE BURNISHING SOLUTION

Good results can be expected from the Burnisher only if it is operated with clean burnishing solution. The solution must be changed when it becomes clouded in appearance. With normal use, this is after eight hours of operation.

SOLUTION CHANGE PROCEDURES

To change the burnishing solution, perform the following steps:

1. Remove all silverware from the drum and replace the cover on the drum.
2. Making sure that the cover is securely locked in place, remove the drain cap covers and install the fill and drain hoses. THE DRUM MUST BE UPRIGHT WITH THE COVER AT THE TOP POSITION TO ALLOW THE DRAIN AND FILL ATTACHMENTS OF THE HOSES TO PENETRATE THE BURNISHING BALLS IN THE BOTTOM OF THE DRUM. With the drain hose leading to a sufficient waste drain, attach the fill hose to the house water supply. The drain must be at a lower level than the bottom of the burnishing drum. CONSULT LOCAL PLUMBING CODES FOR REGIONAL REQUIREMENTS. See Figure 2.
3. Turn the water on, allowing it to flow into the burnishing drum and out the drain hose. Cold water is sufficient. When water flows clear from the drain hose, turn off the water supply to the fill hose and disconnect the fill hose from the faucet. Allow water to continue draining from the drum until no more will drain. The drum is now half filled with water. This is the correct amount of water for preparation of new burnishing solution.
4. Remove the drain and fill hoses from the drum cover and replace the drain cap covers.
5. Remove the drum cover and add the EG Rotary Burnishing Liquid to replenish the burnishing solution as previously explained.

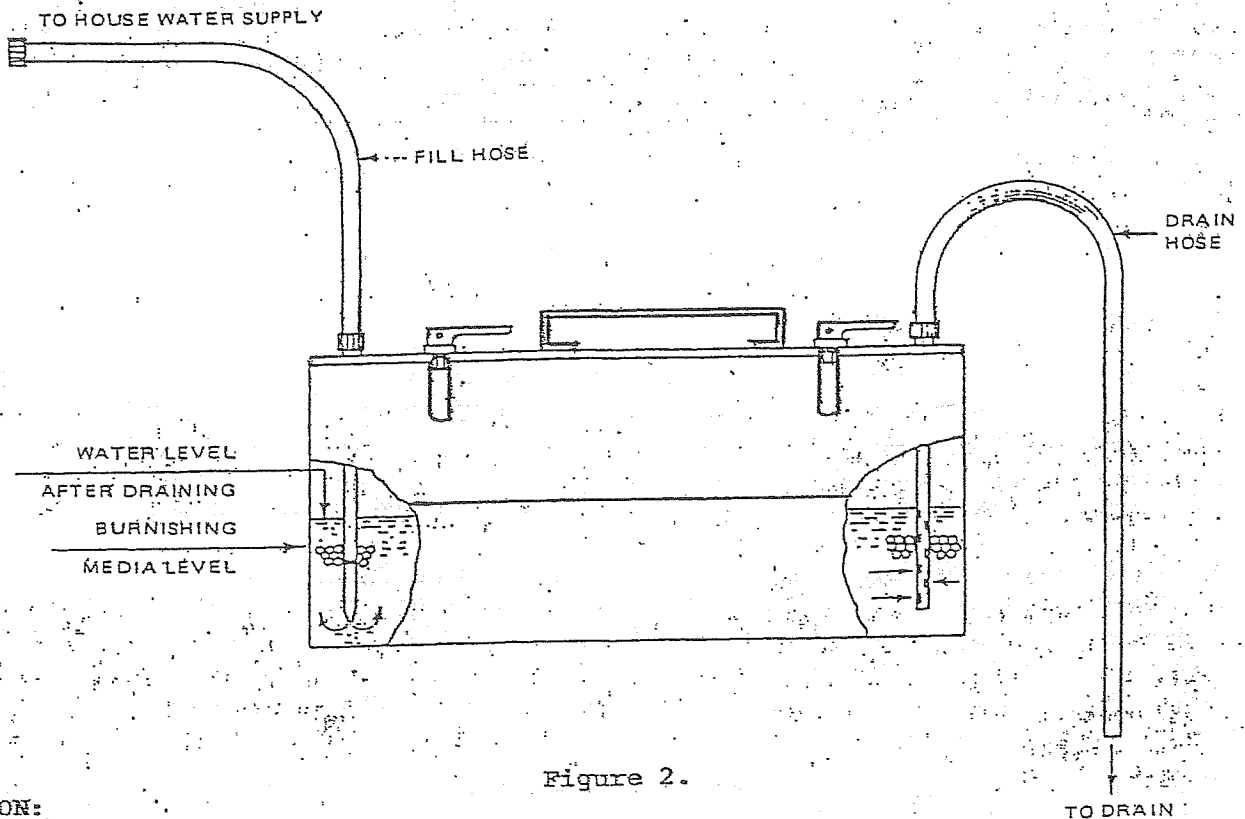

Figure 2.

CAUTION:

To prevent rusting, never leave the burnishing balls exposed to air. They must always be submerged in EG Liquid solution.

6. If the machine is to be immediately re-used, load with silverware, replace the cover, and resume operation.
7. If the machine is not to be used immediately, it is necessary to mix the EG

SILVERWARE PROCESSING

For the best maintenance of silverware, it is recommended that a routine burnishing schedule be followed. Required frequency of burnishing depends upon the silverware utilization rate and the tarnish and scratch resistance of the specific silver. Maintaining silver in sufficiently burnished condition can increase its life and facilitate washing. Burnishing is best considered as one step in the total processing of silverware. Complete processing includes the following:

1. Washing - Silverware must first be thoroughly washed of food soil and grease, all of which prevent contact of detarnishing agents with the surface.
2. Detarnishing - Through detarnishing, sulphide compounds of silver are removed from the silverware. Chemical detarnishing agents are available through local suppliers or Adamation. For ordering information see Section 6, Illustrated Parts List. (For information about Adamation detarnishing sinks consult the factory.)
3. Rinsing - Detarnishing solutions must be completely removed from the silverware before the silverware is loaded into the burnishing drum. Residue can damage the silverware by becoming embedded into the soft metal surface.
4. Burnishing - Through burnishing silverware becomes highly polished and surface-hardened. Burnished silverware exhibits a high luster, and resists tarnishing.
5. Washing - Silverware must be thoroughly washed after burnishing to ensure sanitation.

PREPARATION OF NEW SILVERWARE

Some new silverware is coated with silver rouge when purchased. This rouge coating which cannot be seen on the silverware combines chemically with the burnishing solution to leave a blue-gray residue on the silver. Before loading new silverware for burnishing, always wash it to remove as much of the coating as possible. The coating of silver rouge which remains, even after washing, will still result in the formation of residue during burnishing. This residue is removed by a second washing.

SECTION 4 THEORY OF BURNISHING

THE BURNISHING PROCESS

Burnishing is a process which combines polishing and surface hardening without utilizing abrasives which remove metal. Though a metal may appear to exhibit an even uninterrupted surface, it is in reality composed of tightly packed individual particles. The principal of burnishing provides that the hardness and shininess of metals can be enhanced through manipulation of the surface metal.

An examination of the structure of a well burnished piece of silverware reveals a smooth surface. The surface is free of scratches and residue of silver sulphide (tarnish). Through normal use, metalware receives multiple small scratches. In addition, sulphur dioxide in the air acts upon the edges of scratches to make them jagged and raised. The result is metalware which exhibits low luster and a rough surface texture.

The burnishing process corrects the imperfections resulting from normal use by repeatedly striking the metalware with smooth, heavy objects - the burnishing balls. The balls roll down raised scratches while slipping surface metal to fill depressions. At the same time these imperfections are being removed, the metalware surface is being flushed of small amounts of silver sulphide not removed in detarnishing.

The result of this "compacting" of the metal surface is a smooth "work hardened" surface which not only improves the appearance of the silver, but also makes it more scratch resistant and easier to clean.

HOW THE ROTARY BURNISHER WORKS

In the model EG-2 Burnisher, highly polished 1/4-inch-diameter steel burnishing balls are used. The mass of steel balls is placed in motion by the hexagonal burnishing drum. An unbalance results from the mass being lifted up on one side of the drum while being pushed down on the opposite side. The result is a continuous sliding of the mass from the high to low side thus creating an area called the "slide zone". It is in this zone that individual steel balls have the greatest striking force for burnishing. See Figure 3 for a diagrammatic description.

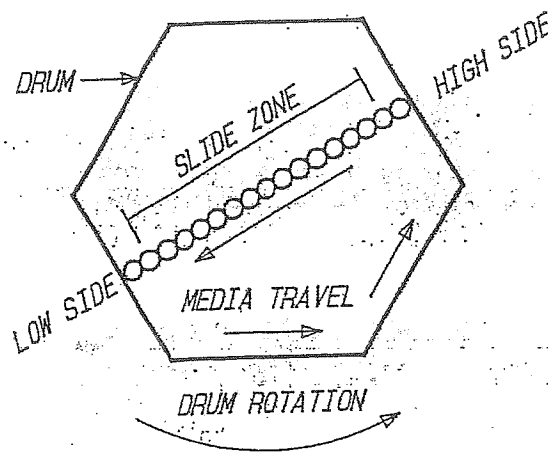

MEDIA MOTION DIAGRAM
FIGURE 3

Silverware in the drum is caused to travel with the mass of balls, repeatedly being carried into the slide zone. Burnishing of the silverware results from the collective effect of multiple impacts with the balls in the zone. The force of contacts of silverware with other silver are not injurious when they occur in a sliding action. Impacts received between silverware in an overloaded drum arise through cascading of silver, and can be damaging to the soft silver metal. GOOD RESULTS ARE OBTAINED FROM THIS MACHINE ONLY WHEN OPERATED AT OR BELOW THE RECOMMENDED LOADING LEVEL.

The EG Liquid and water solution plays a two-part role in the burnishing process. First, as a lubricant, it ensures easy motion of the mass of balls and silverware, thus preventing damaging abrasion. Second, as a cleaning agent, the solution carries sulphides and other foreign elements away from the silver surface. The limited capacity of the solution for holding these elements requires that it be changed at regular intervals as recommended in Section 3.

SECTION 5 MAINTENANCE

GENERAL

This section contains both preventive and corrective maintenance information. Preventive maintenance is limited to little more than cleaning, all of which can be performed by the operator. Corrective maintenance can be performed by maintenance personnel. For aid in corrective maintenance, consult the National Service Department. (See Section 6)

PREVENTIVE MAINTENANCE

Maintaining clean burnishing solution is extremely important to the correct functioning of this machine. Sufficiently frequent replacement of the burnishing solution ensures that time consuming cleaning of the burnishing balls will not be necessary.

MACHINE CLEANING

Thorough cleaning of the entire machine should be completed after each period of operation. Cleanliness of the exterior of the burnishing drum and other machine parts is accomplished by wiping with a mild soap solution which removes dirt and burnishing solution spill stains. Rinse with clear water.

SHINING MACHINE PARTS

The appearance of the stainless steel parts can be improved by removing grease marks such as finger prints, which remain even after washing. Application of lemon oil or a spray-on furniture polish is suitable for this purpose.

DRIVE BELT TENSION ADJUSTMENTS

Correct adjustment of the drive belt will provide the longest possible wear. Adjustment is made by use of the adjusting knob (23) Figure 4. Turn the knob clockwise to tighten the belt tension (reduce drum slippage). Turn the knob counterclockwise to loosen the belt tension (increase drum slippage). Correct tension is set when the drum rotation remains fully engaged during maximum capacity loading of the drum, but rotation can be interrupted by grasping the drum by hand. NEVER TIGHTEN THE BELT MORE THAN THE TENSION REQUIRED TO ACHIEVE SLIPPAGE FOR OVERLOAD PROTECTION.

COVER SEALING AND ADJUSTMENT

Sealing of the burnishing drum with the cover is effected by a gasket attached to the cover. Correct alignment of the cover assembly with the drum is maintained by the four self-locking latches. These parts are shown as items (4), Figure 4. The explanations in this section will provide aid in the event that these parts fail to seal.

COVER LATCH ADJUSTMENT

Machines are equipped with self-locking latches (4). The self-locking latch is adjusted to compensate for collapsing of the cover gasket as it ages. Adjustment is made by loosening the 5/16 nut and rotating the latches clockwise until sufficient pressure is applied to compress the gasket. Tightening the nut holds the latch in adjustment.

CAUTION:

Never adjust the latches so that the handles are perpendicular to the axis of the drum. Handles so adjusted will cause the drum to become jammed with the motor cover.

GASKET REPLACEMENT

When the gasket becomes excessively worn or damaged, sealing may not be possible. To replace, all traces of the worn gasket are stripped off. The replacement cover gasket (3), which is supplied without nipple holes, is installed with the sponge rubber side cemented to the cover, the smooth side out. Gasket cement is applied to the cover and to the gasket separately and the cement allowed to dry until the surface is no longer tacky. A sheet of kraft paper placed between the cover and the gasket allows the cover to be carefully centered on the gasket before the cemented sides bond together. Remove the paper and attach the cover to the gasket by application of pressure for a twelvehour period.

Refitting of the cover is completed only when the gasket cement is dry. The location of the hole for nipple (1A) is found by sliding a knife point through the drain-cap well on top of the cover and sliding it down the side until the gasket is penetrated. Once the hole location is found, the knife is then used to cut the gasket from the bottom, completing the cutting by following the edge of the drain-cap well. The procedure is repeated for the second drain-cap well.

DRIVE BELT REPLACEMENT

Access to the "V" belt (14), Figure 4 is gained by removing the acorn nuts from belt guard front (15). Turning the adjusting knob (23) counter-clockwise will allow the motor pulley (13) to be raised high enough from the belt to be slipped off. Installation of the replacement belt must be followed by making adjustments of the belt tension as explained on page 10.

DRIVE ASSEMBLY REPAIR

Access to the drive assembly is gained by removal of the panel (15) and the motor cover (6) shown in Figure 4.

The gearhead motor (18) is replaced when either the motor or the gearhead box becomes faulty. These parts are not separately replaceable.

CLEANING THE BURNISHING BALLS

Burnishing balls can become coated with metal compounds through failure to change the burnishing solution as specified, or through burnishing of metals other than silver or stainless steel. Soiled balls exhibit low luster resulting from surface coating with black residue. Coated balls produce poor burnishing results.

Burnishing balls are cleaned by operating the machine with EG Liquid solution as specified for operation in Section 3. No silverware is loaded into the drum during this cleaning period. Progress of cleaning is checked at 30-minute intervals until the solution appears clouded. After repeated changes of the solution, the balls will regain their original luster. The completion of cleaning is followed by a thorough flushing of the balls and replenishing of the EG Liquid solution.

RUST ON THE BURNISHING BALLS

Burnishing balls exposed to the air or to harsh chemicals can become rusted. An immediate inspection should be made of the balls in rusted condition to determine if reclamation is possible. Rust is evidenced by the characteristic reddish-brown coating.

DESTROYED BALLS

Balls in this category have deep pits and breaks in the external surface, as well as a heavy coating of rust. Even if rust is removed from balls in this condition, it will not produce satisfactory burnishing results. These balls should be removed from the drum and replacement balls ordered.

CAUTION:

Do not leave rusted balls in the burnishing drum. Extreme rusting causes fusing of the balls into a single mass which cannot be removed.

NOTE:

Attention should be given to the routine ordering of EG Rotary Burnishing Liquid (Adamation part number 65-7400-506), to ensure that the operating supply is never depleted.

PREPARATION OF THE BALLS FOR STORAGE

Submersion of burnishing balls in EG Liquid solution provides protection from rusting. If the Burnisher is to be placed in storage, as is the custom in seasonal restaurant business, it will be necessary to leave the balls in this condition for an extended length of time. A clean, double strength solution of liquid which completely submerges the balls will protect them from rusting for a full 12-month period - even through freezing. It is essential that the cover be securely fastened in place to eliminate evaporation.

SECTION 6 ILLUSTRATED PARTS LIST

GENERAL

This section contains a complete listing of normally replaceable parts of the model EG-2 Burnisher. Reference numbers coincide with those of the labelled part in the exploded view. Full information for ordering includes the Adamation part number, description and quantity required to complete one unit. Common hardware items should be purchased locally.

ORDERING INFORMATION

Orders for replacement parts should be addressed to:

Adamation, Inc.
National Service Department
87 Adams Street-P.O. Box 37
Newton, Mass. 02195
(617) 244-7500
(800) 225-3075

The order should contain the Adamation part number, the part description and the

ILLUSTRATED PARTS LIST-FIGURE 4

ITEM NUMBER	PART NUMBER	DESCRIPTION	QTY PER ASSY
1	75-0830-606	COVER, DRAIN CAP	2
1A	19-4204-500	WASHER, DRAIN CAP	2
2	22-1418-400	COVER, DRUM SPECIAL	1
3	19-4204-600	GASKET, DRUM COVER. EG-2	1
4	12-1409-900	LATCH ASSY, SELF-LOCKING, W/HARDWARE	4
5	55-1060-301	CORD, SWITCH, 8' LONG	1
6	22-1418-200	PANEL, REMOVABLE, MOTOR COVER, S/S SPECIAL	1
7	55-7400-302	SWITCH, CONTROL, TOGGLE, 115V	1
8	32-1420-300	DRUM, S/S PLASTISOL COATED, SPECIAL	1
9	22-1407-200	HOSE, FILL, 5/8" ID X 6 FEET LONG	1
10	22-1407-100	HOSE, DRAIN, 5/8" ID X 6 FEET LONG	1
11	70-0465-021	BEARING, PILLOW, 3/4" BORE	1
12	70-0455-302	BEARING, FLANGE, 3/4" BORE	1
13	70-6302-001	PULLEY, 5"	2
14	70-0500-541	BELT, V, TYPE A, 4L410, 41"	1
15	22-1418-300	GUARD, BELT, FRONT, SPECIAL	1
16	70-0850-501	CASTER, W/O BRAKE, 4" DIAMETER WHEEL	2
17	70-0850-001	CASTER, W/ BRAKE, 4" DIAMETER WHEEL	2
18	55-5004-025	MOTOR, GEARHEAD	1
19	32-1406-913	NUT, ROCKER, 7/8" X 5/16-18	1
20	60-8850-410	WASHERS, FINISH-SPRING RETAINER	2
21	70-7400-070	SPRING, COMPRESSION, 1" OD X 2" X .125	1
22	32-1406-914	ROD, ADJUSTING, 5/16-18 X 6" LONG	1
23	70-2850-120	KNOB, ADJUSTING, 5/16-18	1

ADAMATION EG ROTARY BURNISHING LIQUID

Adamation's EG Liquid is formulated for use specifically for the EG-2.

Packed in cases containing four one-gallon containers.

PART NUMBER: 65-7400-506

ADAMATION EG-2 BURNISHING BALLS (1/4")

EG-2 Total Capacity is 75 pounds.

75 pounds of 1/4-inch-diameter burnishing balls.

Packed in 25 lb boxes.

PART NUMBER: 65-7300-010

SILVER BLUE INSTANT DIP DETARNISHER

Packed in cases containing four one-gallon containers.

PART NUMBER: 65-7400-550

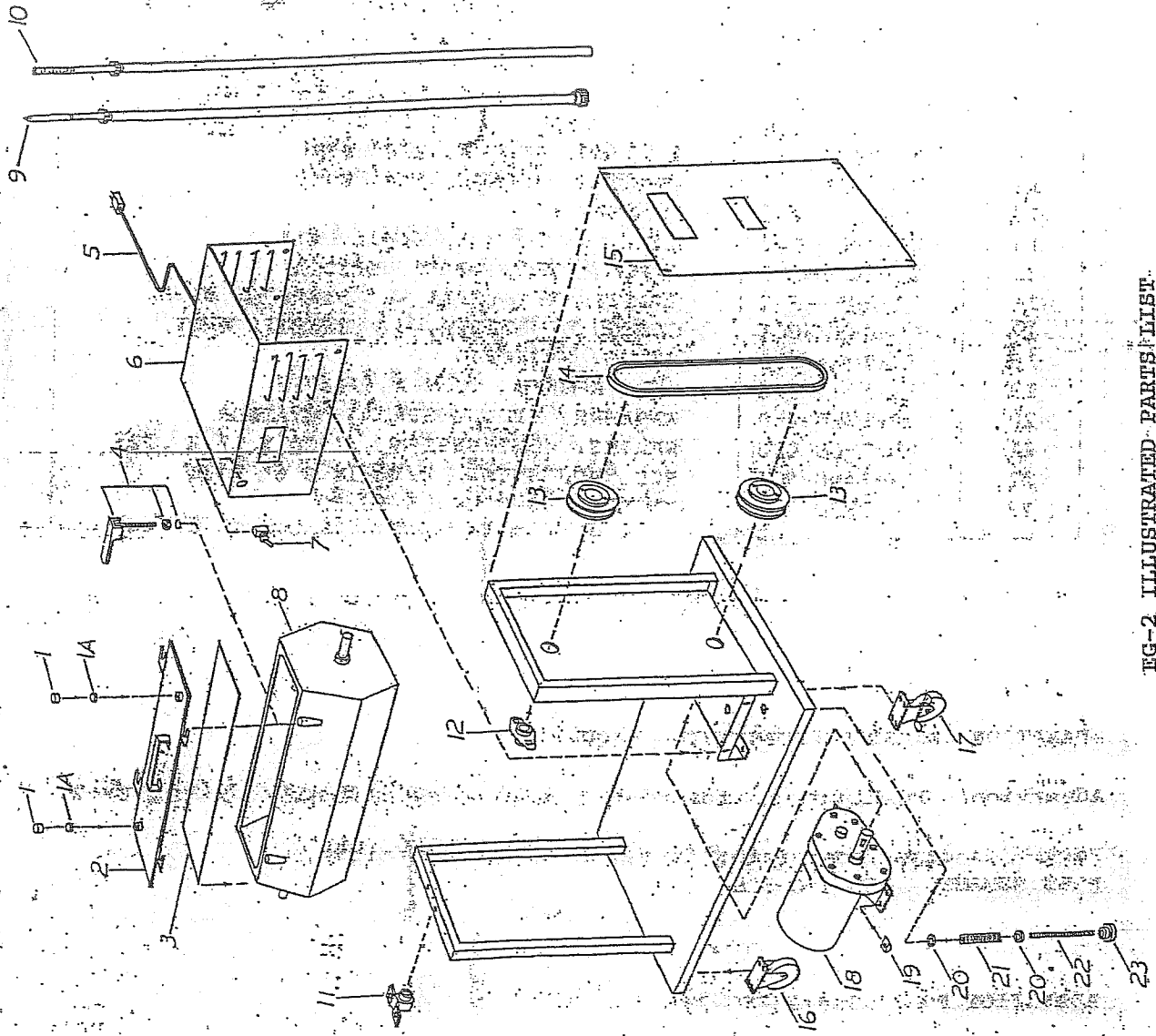

EG-2 ILLUSTRATED PARTS LIST
FIGURE 4