

Adamation

"For Creative Dishwashing Solutions"

P.O. Box 95037, 87 Adams Street, Newton, MA 02495-0037

Tel.: (617) 244-7500 Toll Free: (800) 225-3075 Fax: (617) 244-4609



**OPERATOR'S MANUAL FOR ADAMATION MODEL
VM-126 SILVER BURNISHING MACHINE
CONTAINS INSTRUCTIONS FOR OPERATION,
MAINTENANCE, AND REPAIR**

**Part Number: 99-9000-022
Price: \$ 20.00
Revised October 2001
Printed in U.S.A.**

TABLE OF CONTENTS

Warranty.....	Page 1
---------------	--------

SECTION 1 INTRODUCTION

Machine Description.....	Page 2
Machine Specifications.....	Page 3
Basic Functioning.....	Page 3
Accessories.....	Page 3

SECTION 2 INSTALLATION

Description Of Packaging.....	Page 4
Installation And Assembly.....	Page 4-5

SECTION 3 OPERATION

General.....	Page 6
Filling With Water.....	Page 6
Adding The Powder Or Liquid.....	Page 6-7
Loading And Operating.....	Page 7-8
Changing The Burnishing Solution.....	Page 8
Silverware Processing Schedule.....	Page 8-9
Preparing New Silverware.....	Page 9

SECTION 4 THEORY OF BURNISHING

The Burnishing Process.....	Page 10
The Vibratory Burnisher.....	Page 10-12

SECTION 5 MAINTENANCE

General.....	Page 13
Preventive Maintenance.....	Page 13-14
Corrective Maintenance.....	Page 14-21

SECTION 6 ILLUSTRATED PARTS LIST

General.....	Page 22
Ordering Instructions.....	Page 22-23

WARRANTY

Your Adamation Vibratory Burnisher is warranted for one year. Within twelve months of the date it is put into operation, Adamation will repair any defect in materials or workmanship. Adamation normally ships warranty parts via ground shipment from its factory in Newton, MA with Adamation assuming the ground shipment charges. If the customer elects to utilize an express method of shipping, then the customer shall pay the difference in cost between express shipping charges and ground shipping charges. Warranty service may be obtained by contacting the Adamation National Service Department. For your convenience, our toll free phone number is 800-225-3075.

Because Adamation has no control over the quality, quantity and timeliness of the compounds supplied to the machine or over the methods of operation, the following items are not covered by this warranty:

1. Burnishing balls that become rusty or discolored.
2. Cost of cleaning.
3. Damage caused by unreasonable neglect and carelessness in operation.
4. Damage caused by using burnishing compounds other than those manufactured and sold by Adamation.
5. Damage caused by any modifications to the unit.

Replacement parts are warranted for ninety days or for the remainder of the machine warranty, whichever is longer.

2.

SECTION 1 INTRODUCTION

MACHINE DESCRIPTION

The Adamation Model VM-126 Burnisher is a heavy-duty machine for burnishing silver and stainless steel flatware and hollow ware. The machine consists of three main sections: the burnishing barrel and drive assembly, the water reservoir and pumping system, and the framework and cabinet.

BURNISHING BARREL AND DRIVE ASSEMBLY

The Burnisher is equipped with an open burnishing barrel having inside measurements of 13¼" x 8¼" x 12¼" deep. This is filled with 150 pounds of burnishing balls consisting of 75 pounds of 3/16-inch-diameter and 75 pounds of 1/4 inch-diameter steel balls. A thick vinyl coating on the inside of the barrel prevents deterioration of the steel barrel, chemically isolates it from the burnishing process, and helps reduce the noise of the moving burnishing balls. Springs located between the barrel mounting brackets and the machine mechanically isolate the barrel from other machine parts.

A drive mechanism is integrally mounted to the base of the barrel. It consists of motorized counterweights, which set the barrel and its contents into mechanical vibrations.

WATER RESERVOIR AND PUMPING SYSTEM

The stainless steel water reservoir has a capacity of 6.5 gallons and holds the burnishing solution used in the burnishing process. An oscillating pump circulates the solution through the system. A drain tube is provided to remove dirty or old burnishing solution.

MACHINE FRAMEWORK AND CABINET

The machine cabinet is made of stainless steel and houses the burnishing barrel, the drive mechanism, and the solution circulating system. These are supported by an angle-iron framework. The panels of the cabinet are easily removable for servicing.

MACHINE SPECIFICATIONS

The Adamation Model VM-126 Burnisher is approximately 36 inches long, 20¼ inches wide and 36½ inches high, to the top of the working surface. Standard electrical requirements are 115/230 volts, 60 Hz, single-phase AC service. Other electrical services can be accommodated by special order.

CAPACITY

The Burnisher will burnish any silver or stainless steel pieces that will rotate freely in its vibrating barrel. The machine has a capacity of 100 to 125 pieces of mixed flatware at one time. If the load consists entirely of forks, the capacity is reduced to 75 pieces.

The hollow ware capacity depends entirely on the size and fragility of the pieces. (For instructions on burnishing, see Section 3, "Loading And Operating".)

PRODUCTIVITY

Although the capacity of the Burnisher may be the same as many batch-type rotary burnishers, this machine has a greater production rate because of its continuous operation and faster burnishing action. An experienced operator can burnish about 10 loads of flatware per hour (1000 to 1250 pieces). These figures apply to operations that have an established silver burnishing program.

TRAINING OPERATORS

Operators can be successfully trained quickly. No previous experience is necessary and operators can be shown how to properly run the Burnisher in a few minutes.

BASIC FUNCTIONING

The burnishing function is accomplished in the burnishing barrel loaded with the 1/4" and 3/16" steel burnishing balls. Silverware is burnished by contact with the moving balls. (For a detailed description of the "Theory Of Burnishing", see Section 4.)

ACCESSORIES

LOCKING COVER ASSEMBLY

An optional locking cover assembly is available for the VM-126 Burnisher. The locking cover assembly provides protection against garbage being accidentally or intentionally dumped into the burnishing barrel and also protects against loss of the burnishing media. The cover is equipped with padlock lugs to insure security. (The padlock is not included.)

SECTION 2 INSTALLATION

DESCRIPTION OF PACKAGING

The Model VM-126 Burnisher is skid-mounted for shipping. The machine is encased in a heavy cardboard, "tri-wall" sleeve and cover. A case of VM Burnishing Powder is shipped in a separate carton. The burnishing balls are packed in six 25 lbs. boxes inside the container on the skid.

Internally, the machine is protected against shipping damage by two wooden blocks inserted between the burnishing barrel and its frame. Metal strapping around the barrel and frame restrains movement during shipment.

INSTALLATION AND ASSEMBLY

REMOVING THE PACKING CARTON

The entire top section of the carton can be removed by cutting the strapping. The remaining carton walls slide off the machine allowing the Burnisher to be carefully removed from the skid.

REMOVING INTERNAL PACKING MATERIAL

The front and rear panels of the machine are removed by grasping the bottom edge, lifting up, and pulling out at the bottom, then sliding the panels down and out. The metal hold-down straps are cut from around the barrel and frame, and discarded. The two wooden blocks under the barrel edge are removed by lifting up on the barrel.

BARREL INSTALLATION CHECK

The large springs supporting the barrel must be seated correctly in their top and bottom guides before operating the machine. A firm grip on the barrel and a sharp shake may be all that is needed to seat them properly if they are slightly misaligned. If one of the springs is severely out of position, lifting up the barrel as described in Section 2, "Removing Internal Packing Material", will allow it to be correctly positioned.

ELECTRICAL SERVICE

Before plugging the machine into a wall outlet, make sure that the correct electrical service is available. Electrical requirements for the machine are shown on the identification nameplate.

LOADING THE BURNISHING BALLS

The machine is shipped with 150 pounds of specially sized burnishing balls as described in Section 1, Burnishing Barrel And Drive Assembly. All shipment is made with the balls inside the shipping carton. The balls are contained in six 25 lbs. boxes, which are emptied into the barrel of the machine. The level of the burnishing balls should be within 4½ inches of the top of the barrel and should be maintained at this level.

NOTE:

Use only the balls supplied with the machine. If replacements are necessary, use approximately a 50% to 50% mixture of 1/4" and 3/16" steel balls. (See Section 1, "Burnishing Barrel And Drive Assembly".) Do not use balls smaller than 3/16" diameter, as they will clog the drain holes in the barrel.

PRE-OPERATION CHECK

The following items must be checked in the order listed before operating the Burnisher:

- 1.** With the front and back panels removed, check to be sure that all packing material has been removed from the inside of the machine.
- 2.** Check the barrel mounting springs to be sure that they are seated properly.
- 3.** Check all hose connections to be sure that they are correct and tight.
- 4.** Check that the drain hose is securely inserted in the ring at the end of the machine.
- 5.** Replace the front and back panels.
- 6.** Close the drain valve on the reservoir.

CAUTION:

Read the operating instructions before running the Burnisher. Serious damage to the burnishing balls may occur if the instructions are not followed carefully.

SECTION 3 OPERATION

GENERAL

This section should be read thoroughly before operating the Burnisher. The section is intended for training new personnel and for reacquainting present operators with proper procedures. For initial operation, the procedures contained in Section 2, "INSTALLATION" must be completed before the machine is operable.

FILLING WITH WATER

The reservoir is filled with cold water to the level indicated by the line marked "FILL TO HERE" on the inside of the tank.

NOTE:

Reservoir should not be hard plumbed direct from incoming water supply. Doing so will void warranty.

ADDING THE POWDER OR LIQUID

CAUTION:

Never operate the machine without burnishing powder or liquid, as serious damage to the burnishing balls will result.

To add the powder or liquid: one half of a packet of VM Burnishing Powder (Part Number 65-7400-505) is poured directly on the burnishing balls or four ounces of VM Burnishing Liquid is added to the reservoir. The machine is then run without silverware for at least ten minutes to thoroughly mix the compound.

NOTE:

White spots may occur on silver that is burnished before running the machine empty for at least ten minutes to dissolve the compound. Additional burnishing will be required to remove spots resulting from premature loading.

Adamation manufactures powdered and liquid compounds specifically formulated for this machine and labeled "VM" (for Vibratory Machine) burnishing compound. Do not use "EG" compound, which is designed for rotary burnishers and will not work in this machine nor will it protect the burnishing balls.

Substitution of any other brand of burnishing solution will probably result in poor results and rusted burnishing balls. A sufficient supply of Adamation Burnishing VM Powder or Adamation Burnishing Liquid should always be kept on hand. (See Section 6, "Illustrated Parts List", for ordering information.)

LOADING AND OPERATING

STARTING UP

After charging the machine with a fresh solution and running it for at least ten minutes to mix the solution, the machine can be utilized for burnishing. (The machine should be left with a fresh solution in it at the end of each working day. It is not necessary to change this solution at the beginning of the next day.)

The balls assume the position shown in "Figure 1" when the machine is in operation. Cleaned and detarnished silverware or stainless ware is put into the machine while it is running by placing the pieces on top of the burnishing balls inside the vibrating barrel. The silver rotates within the mass of the burnishing balls and returns to the top.

NOTE:

Only load a few pieces at a time into the machine. Dumping in the whole load at once will cause damage to the silverware as well as inhibit the burnishing process. Never put dirty or tarnished silverware into the Burnisher.

CAPACITY

The Adamation VM-126 Burnisher is capable of burnishing any silver or stainless piece that will circulate freely within its barrel. The capacity of the machine depends on the type of silver or stainless being burnished. 100-125 pieces of mixed flatware can be burnished at one time. If the load consists entirely of forks, the capacity is reduced to 75 pieces. The capacity of the machine for hollow ware depends on its size and fragility.

CAUTION:

Overloading the machine can seriously damage the silver.

TIME REQUIRED

The time required for burnishing depends upon the condition of the surface of the silver to be processed. Silver that is burnished regularly requires as little as four minutes, while badly scratched pieces may require a first treatment of 20 to 30 minutes.

8.

The operator determines when the burnishing of a piece is completed by inspecting it as it returns to the top of the burnishing balls. When the smoothness and shine have been restored, the piece is removed from the machine.

CHANGING THE BURNISHING SOLUTION

NOTE:

The burnishing solution should be changed as soon as it becomes dirty or after four hours of use. In any case, it should be changed after the last load of silverware is burnished each day.

All silverware must be removed from the barrel and the machine turned off before changing the solution. The reservoir is drained by lowering the drain hose to the floor. Then the procedures in Section 3, "Filling With Water And Adding The Powder Or Liquid" are followed.

CAUTION:

Never operate the machine with dirty burnishing solution. Doing so will cause the burnishing balls to become dirty. This condition takes several hours to correct. Therefore, always change the burnishing solution regularly.

It takes only a few minutes to change the burnishing solution. The time involved in cleaning dirty burnishing balls can be as much as six hours. The time saving realized by regularly changing the burnishing solution is worth the effort.

CAUTION:

Never wash the burnishing balls with water or rinse them with a hose even if they are dirty or rusty. See Section 5, "Burnishing Balls - Problem B" for instructions for cleaning the balls.

SILVERWARE PROCESSING SCHEDULE

SCHEDULED BURNISHING

For the best maintenance of silverware, a routine burnishing schedule is recommended. The frequency of burnishing required depends on the frequency of use of the silverware and the tarnish and scratch resistance of the particular pattern. Maintaining burnished silverware increases the life of the piece and facilitates washing.

SILVERWARE PROCESSING

Burnishing is best considered as one step in the total processing of silverware. A complete processing program includes the following:

- 1.** Washing – Silverware must be thoroughly washed, free of food soil and grease, as these would otherwise interfere with the contact of the surface with detarnishing agents.
- 2.** Detarnishing – Detarnishing removes sulfide compounds of silver (tarnish) from the surface of the silverware. Chemical detarnishing agents are readily available through local suppliers or Adamation. For ordering information, see Section 6, "Illustrated Parts List". (For information about Adamation detarnishing sink, consult the factory.)
- 3.** Rinsing – Detarnishing solutions must be completely removed from silverware before it is loaded into the burnisher. Residue can damage silver by becoming imbedded in the soft metal surface.
- 4.** Burnishing – Silverware becomes highly polished and "surface-hardened" through burnishing. Burnished silverware exhibits a high luster, resists tarnishing, and is easier to wash.
- 5.** Washing – For proper sanitation, silverware must be thoroughly rinsed after burnishing.

PREPARING NEW SILVERWARE

Some new silverware is factory-coated with "silver rough", a manufacturers' polish and tarnish preventive. This rough, which cannot be seen on the silverware, combines chemically with the burnishing solution leaving a blue-gray residue after burnishing. Therefore, before burnishing new silverware, it is advisable to wash it to remove as much of the coating as possible. Some coating of rough that remains even after washing still results in the formation of some residue during burnishing. This residue is removed by washing after the burnishing process is completed.

SECTION 4 THEORY OF BURNISHING

THE BURNISHING PROCESS

Burnishing is a process, which combines polishing and surface hardening without using metal-removing abrasives. Though a metal surface may appear to exhibit an even, uninterrupted surface, in reality it is composed of tightly packed individual grains. The principal of burnishing provides that the hardness and shininess of metals can be enhanced through manipulation of these particles.

An examination of a well burnished piece of silver reveals a smooth surface, free of scratches and without a residue of silver sulfide (tarnish). Through normal use, metal ware receives multiple small scratches. In addition, sulfur dioxide in the air acts upon the edges of the scratches to make them jagged and raised resulting in metal ware, which is low in luster and rough in surface texture.

The burnishing process corrects these imperfections by tumbling the metal ware in a burnishing media of smooth heavy objects. The media compacts the surface, rolls down scratches, and slips surface metal to fill in depressions. At the same time, the metal ware is flushed free of the small amounts of silver sulfide not removed in detarnishing. The result of this compacting is a shiny, hardened surface, which not only improves the appearance of the silver, but also makes it more scratch resistant and easier to clean.

THE VIBRATORY BURNISHER

The Model VM-126 Burnisher uses burnishing balls consisting of highly polished 3/16" and 1/4" steel balls. This mass of steel balls is put into motion by the vibrations of the burnishing barrel. This causes the mass to be lifted up on one side of the barrel while being pushed down on the other side. The result is a continuous sliding of the mass from the high to the low side creating an area called the "slide zone". It is in this zone that individual steel balls have the greatest striking force for burnishing. (See Figure 1 for a diagrammatic description.)

Silverware in the barrel travels with the mass of the balls and is repeatedly being carried into the slide zone. The burnishing results from the collective effect of multiple impacts with the balls in the zone.

The force of contact of the silverware with other ware is not injurious if it occurs with this sliding action. Impacts between silverware pieces in an overloaded barrel arise through cascading of the ware and can be damaging to the soft metal surface.

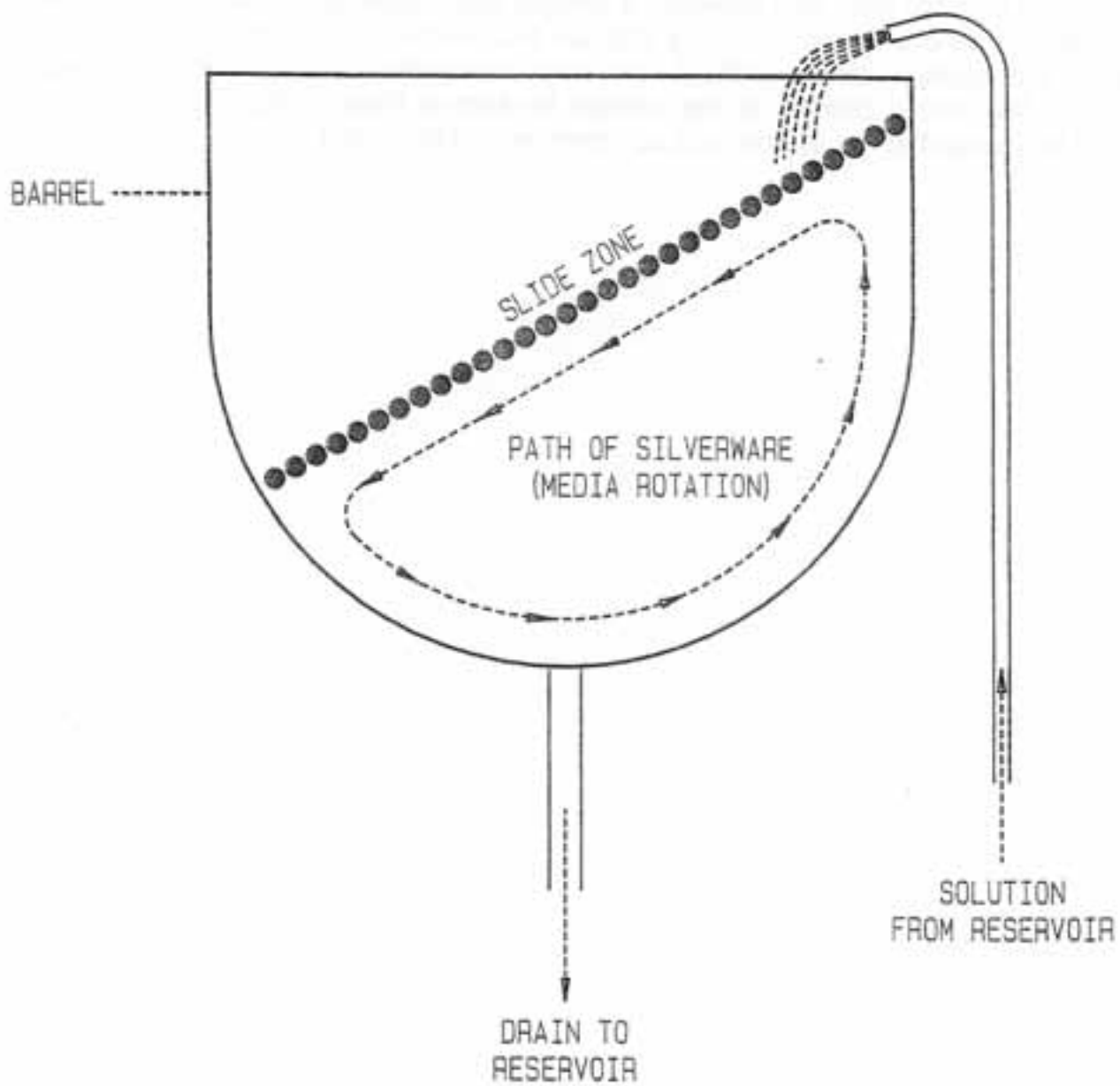

FIGURE 1

A DIAGRAM OF VIBRATORY BURNISHING

12.

NOTE:

Optimum results are obtained with the Burnisher only when it is operated at or below the recommended loading level. For machine capacities, see Section 3, "Capacity".

The water and VM Burnishing Power (or Liquid) solution plays a two-part role in the burnishing process. First, as a lubricant, it ensures easy motion of the mass of balls and silverware, thus preventing damaging abrasion and overheating. Second, as a cleaning agent, the solution carries sulfides and other contaminants away from the silver surface. The limited capacity of the solution for holding these contaminants requires that it be changed at regular intervals as recommended in Section 3.

SECTION 5 MAINTENANCE

GENERAL

This section contains both preventive and corrective maintenance information. Cleaning by the operator is largely the extent of the preventive maintenance required. Corrective maintenance often does not require outside servicemen. However, if in-house maintenance services cannot solve a problem, an Adamation Service Facility should be consulted.

PREVENTIVE MAINTENANCE

CHANGING BURNISHING SOLUTION

Maintaining a clean burnishing solution as described in Section 3 is extremely important to the correct functioning of this Burnisher. Replacing the burnishing solution with sufficient frequency insures that the time-consuming cleaning of the burnishing balls will not be necessary. (See Section 5, "Burnishing Balls – Problem D" for instructions in the event that your supply of VM Burnishing Powder-or Liquid-is exhausted.)

CLEANING THE BURNISHER

Thorough cleaning of the entire Burnisher should be completed after each period of operation. The exterior of the machine can be cleaned by wiping it with a mild soap and water solution. It should be thoroughly rinsed after washing.

NOTE:

DO NOT RINSE the machine with a hose. If water gets into the burnishing barrel, it will dilute the solution causing it to lose its rust-inhibiting properties. Water seeping into the interior of the machine may also cause short circuits or belt slippage.

SHINING MACHINE PARTS

The appearance of the stainless steel parts can be improved by first washing them thoroughly as described in Section 5, "Cleaning The Machine" and then polishing. Lemon oil or any commercial stainless steel cleaner may be used.

14.

STORAGE

At the end of the day, the machine is left filled with fresh burnishing solution. (See Section 3, "Filling With Water And Adding The Powder Or Liquid".). If the Burnisher will not be used for a period of time, the procedure outlined in Section 5, "Burnishing Balls – Problem D" should be followed to prevent permanent damage.

CORRECTIVE MAINTENANCE

This section is arranged according to the Burnisher's systems. Under each system, most of the problems that can arise are listed with their solutions or explanations. If a problem comes up which is not covered, the nearest authorized Adamation Service Representative should be contacted. Consult Adamation's National Service Department if necessary (See Section 6).

WARNING:

Turn the disconnect switch to "OFF" before starting to work on the Burnisher.

CABINET – PROBLEM A:

Removing And Replacing The Front And Rear Panels:

Grasp the panel at the bottom, lift up and pull the bottom toward you. Then pull down and out to release the panel completely. To replace, insert the upper sides in the vertical grooves and slide the panel up and under the overhang of the tabletop. Push the bottom in and pull the panel down into position to lock it in place.

BARREL – PROBLEM A:

Excessive Foaming, Sudsing, Or Splashing:

- 1.** The barrel line or hose may be crimped.
- 2.** Excessive amounts of VM Burnishing Powder or Liquid may have been used. (See Section 3, "Adding The Powder Or Liquid".)
- 3.** A solution other than VM Burnishing Powder or Liquid was used. (See Section 3, "Adding The Powder or Liquid".)

4. The drain slots in the lining of the barrel are clogged. This may be determined by removing the front panel and observing the flow of water through the clear plastic tube leading from the side of the barrel to the drain. Make this observation while the machine is running.

WARNING:

Stand clear of the drive pulleys and belt & the rotating counterweights or serious injury may result.

If the drain holes are found to be clogged, remove the burnishing balls from the barrel and flush or probe the drain holes until they are clear. ***DO NOT attempt to drill these holes out; the holes are not round and permanent damage will occur if they are drilled.***

BARREL – PROBLEM B:

Damage To The Vinyl Lining Of Barrel:

The lining is bonded to the barrel. Tears, cuts or loosening from the barrel most often (caused by use of an unauthorized solution) requires replacement of the barrel. (See Section 5, "Special Instructions For Changing The Burnishing Barrel".)

BARREL – PROBLEM C:

Improper Or No Vibratory Motion Of Barrel (See also Section 5, "Burnishing Balls – Problem A"):

1. The pulley on either side of the motor shaft or drive shaft is cracked, resulting in the loss of the shaft key.
2. The pulleys on the shaft and motor are reversed. However, these pulleys are intentionally reversed for 50-cycle operation.
3. The motor mounting bolts are loose causing loss of tension in the "V" belt.
4. The "V" belt is broken.
5. The water is not draining properly.
6. There has been a failure in the solution supply. Check the hoses and the pump.

16.

- 7.** The tank water has overheated due to friction. Allow the water to cool before continuing to burnish the silverware or change the solution following the instructions in Section 3, "Changing The Burnishing Solution."
- 8.** There was no Adamation VM Burnishing Powder or Liquid in the machine when it was last operated or there is no burnishing solution in the water now.
- 9.** The barrel is overloaded with silverware.
- 10.** The barrel was loaded with silverware before the machine was started.
- 11.** The water has an unusually high mineral content (hard water). Have the water tested and contact the Adamation factory with the test results before using the VM Burnishing Powder or Liquid.

BURNISHING BALLS – PROBLEM A:

Incorrect Movement Of The Balls:

Figure 1 shows the correct position of the balls while the machine is running. (See also Section 5, "Barrel – Problem C".)

- 1.** The machine has not run long enough to become charged with the proper quantity of solution to insure the correct action of the balls.
- 2.** The barrel has been loaded with silver before starting the machine.
- 3.** The Adamation VM Burnishing Powder or Liquid has not been added to the burnishing solution or was added to the water in the tank instead of directly onto the balls.
- 4.** Too much solution was added resulting in excessive suds.

NOTE:

Local water conditions may vary the amount of solution needed. One half packet of Adamation VM Burnishing Powder or 4 ounces of Adamation Burnishing Liquid should be sufficient for areas with "average" water conditions.

- 5.** There is no burnishing solution flowing into the barrel. See Section 5, "Plumbing" and Section 5, "Electrical."

BURNISHING BALLS – PROBLEM B:*Dirty Or Rusty Burnishing Balls:*

- 1.** This is the result of reusing a solution that is dirty, using a solution other than Adamation VM Powder or Liquid, or of using too little solution.

To restore the burnishing balls to their original brightness, first drain the reservoir and refill it with plain cold water. Next add two packages of VM Burnishing Powder or twelve ounces of VM Burnishing Liquid directly onto the burnishing balls. Now run the Burnisher until the water becomes dirty. Drain the reservoir and repeat this procedure until the balls are bright. Finally, refill the reservoir with cold water and add one packet of Adamation VM Burnishing Powder or six ounces of Liquid directly onto the burnishing balls. Run the machine for at least 10 minutes to mix the solution before using the machine for burnishing.

Since this procedure can take as long as six hours, it is well worthwhile to change the solution regularly in the future. (See Section 3, "Changing The Burnishing Solution".)

CAUTION:

Never rinse the burnishing balls with a hose or wash them with water.

If the burnishing balls have rusted into a solid mass, they are beyond repair and must be replaced. See Section 6, "Illustrated Parts List" for ordering information.

If the burnishing balls are still loose, but are coated with rust, follow the above procedure. If this fails to remove the rust completely, new burnishing balls must be purchased.

NOTE:

After cleaning the burnishing balls, inspect them for pitting and wearing before reusing them. If the balls are visibly pitted, they will not produce satisfactory results. See Section 6, "Illustrated Parts List" for replacement information.

BURNISHING BALLS – PROBLEM C:*Dirty Burnishing Balls, Metallic Coating:*

- 1.** This is the result of burnishing aluminum or pewter-like materials. To restore the burnishing balls to their original condition, follow the procedure above.

BURNISHING BALLS – PROBLEM D:

Emergency Storage Of Burnishing Balls To Prevent Rust:

1. If the machine will not be used for a considerable period of time, follow these directions for safe storage of the burnishing balls:

If a supply of VM Burnishing Powder remains, drain the reservoir and refill it with fresh cold water. Add two packets of Adamation VM Burnishing Powder directly to the burnishing balls. Run the machine for a minimum of 20 minutes to mix the compound thoroughly. Shut the machine off and cover the top of the barrel tightly to prevent evaporation of the compound solution. If it is at all possible the machine should be run for ten minutes each week (without silver) to recoat the balls with solution. If rust appears, follow the cleaning procedure and repeat this procedure again using two packets of VM Burnishing Powder.

PLUMBING – PROBLEM A:

No Water Flows Into Barrel From The Inlet Opening:

1. The oscillating pump has failed. Check the pump first by touching it carefully to see if it is vibrating. The pump should vibrate rapidly. If it does not, see Section 5, "Electrical".
2. If the pump is vibrating but not pumping, disconnect the hose to the inlet and back flush the line or remove the feed tube from the reservoir and flush water through it. This will either prime the pump or dislodge any obstruction in the pump. If this does not start the solution flowing, and all other systems are all right, then replace the pump.
3. There is a crimp in the small hose from the pump to the inlet opening.
4. The reservoir is not filled to the indicated level. Drain, refill and add solution.
5. The inlet tube to the pump is clogged where it is attached to the reservoir.

PLUMBING – PROBLEM B:

Leaks:

1. Locate the faulty hose connections. Reconnect the hose firmly. If the hose has aged sufficiently to prevent it from being firmly attached, it should be replaced.

ELECTRICAL – PROBLEM A:

The Oscillating Pump Does Not Vibrate:

1. Unplug the power cord and check all electrical connections to the pump. Pay special attention to the small rectifier (diode) in the line. Be sure that the rectifier connection clip has not become separated from its wire connection clip. If all connections are all right and if the rectifier is not burned out, replace the pump.

ELECTRICAL – PROBLEM B:

The Machine Does Not Start:

1. Check the circuit breakers or fuse in the power supply line to the Burnisher.
2. Unplug the plug from the outlet. Open the electric starter box and check the connections to the power supply.
3. Check the overload heater in the power switch.
4. There are broken leads inside the conduit box on the motor.
5. There are burned out or broken windings on the motor. Check by taking an amperage reading.

NOTE:

When servicing the motor, it is most important to replace the "Duxseal" mastic inside the motor conduit box to prevent movement and subsequent breakage of the wires inside. Use only "Johns Manville" brand or order from Adamation.

UNUSUAL NOISES – PROBLEM A:

The Unit Starts With Loud Screech Then Quiets Down:

1. The drive belt is loose. This belt should have only 1/2" free play between the pulleys.
2. The motor mounts are loose, thus allowing the motor to pitch slightly sideways towards the belt.
3. The drive belt is badly worn. Replace the belt.

20.

UNUSUAL NOISES – PROBLEM B:

There Is A Rapping Noise When The Machine Is In Operation:

- 1.** The setscrews on the pulley are loose allowing the pulley to wander on the shaft.
- 2.** The motor mounting bolts are loose. They must be tightened to a minimum of 40 ft.-lb. of torque.
- 3.** There has been a bearing failure.

NOTE:

It is characteristic for the bearings to bleed slightly while the Burnisher is still new.

- 4.** The setscrews on the eccentrics (weights) are loose allowing the eccentrics to slap on the shaft.
- 5.** There is free play in the drive belt. This belt should have only 1/2" free play.
- 6.** There has been a bearing failure in the drive motor.
- 7.** The setscrews in the bearing collar on the drive side of the motor shaft are loose.
- 8.** There is a clipped or broken drive shaft pulley.

UNUSUAL NOISES – PROBLEM C:

Excessive Transmission Of Vibration And Noise:

- 1.** The machine is not set reasonably level.
- 2.** The two locking casters are not locked.
- 3.** The springs are not properly seated on the frame of the barrel.
- 4.** There is not enough water in the reservoir and barrel.

NOTE:

If the problem you are having with your Burnisher is not mentioned in this section, or if the solutions listed do not solve the problem, please contact:

Adamation
National Service Department
87 Adams Street
P.O. Box 95037
Newton, Massachusetts 02495-0037
U.S.A.
Phone: (617) 244-7500
(800) 225-3075
FAX: (617) 244-4609

SECTION 6 ILLUSTRATED PARTS LIST

GENERAL

This section is a complete listing of all of the replaceable parts on the Adamation VM-126 Burnisher. The lists coordinate with exploded view drawings for easy identification of the parts. The reference numbers in the list refer to those in these drawings.

One abbreviation is used: NPN. NPN stands for "no part number". This is used on part descriptions that are parts of a larger assembly and are not available separately.

ORDERING INFORMATION

All listed parts are available directly from Adamation and from its network of parts distribution centers, service offices and service representatives. Parts should be ordered directly from the service facility nearest you. Orders should include the quantity needed, the exact part number listed, and the description as given in the list.

All goods are sold FOB Newton, Massachusetts, freight prepaid and charged as a separate item on the invoice unless otherwise requested. Minimum order is \$35.00. Orders are subject to the approval of the Adamation credit department. The company's terms are Net 30 days. Also, for the convenience of our customers, orders may be charged to MasterCard, Visa or American Express. Price information is available from the nearest Adamation service facility or from the address below.

Orders from outside the United States should be referred to the address below. Orders unable to be processed through the nearest service facility should also be referred to the following address:

Adamation
National Order Department
87 Adams Street
P.O. Box 95037
Newton, Massachusetts 02495-0037
U.S.A.

ADAMATION VM BURNISHING POWDER AND LIQUID

Adamation's VM Powder and Liquid are formulated for use specifically for the VM-126.

POWDER: Packed in 52 individual packets per case.

PART NUMBER: 65-7400-505

LIQUID: Packed in cases containing four one-gallon containers.

PART NUMBER: 65-7400-502

ADAMATION VM-126 BURNISHING BALLS

VM-126 Burnisher's total capacity is 150 pounds, as follows:

75 pounds of 3/16-inch-diameter burnishing balls and

75 pounds of 1/4-inch-diameter burnishing balls.

Each is packed in 25 lb. sealed "rust-inhibited" boxes:

3/16-inch-diameter PART NUMBER: 65-7300-001

1/4-inch-diameter PART NUMBER: 65-7300-010

ADAMATION INSTANT SILVER CLEANER AND DETARNISHER

Packed in cases containing four one-gallon containers.

PART NUMBER: 65-7400-550

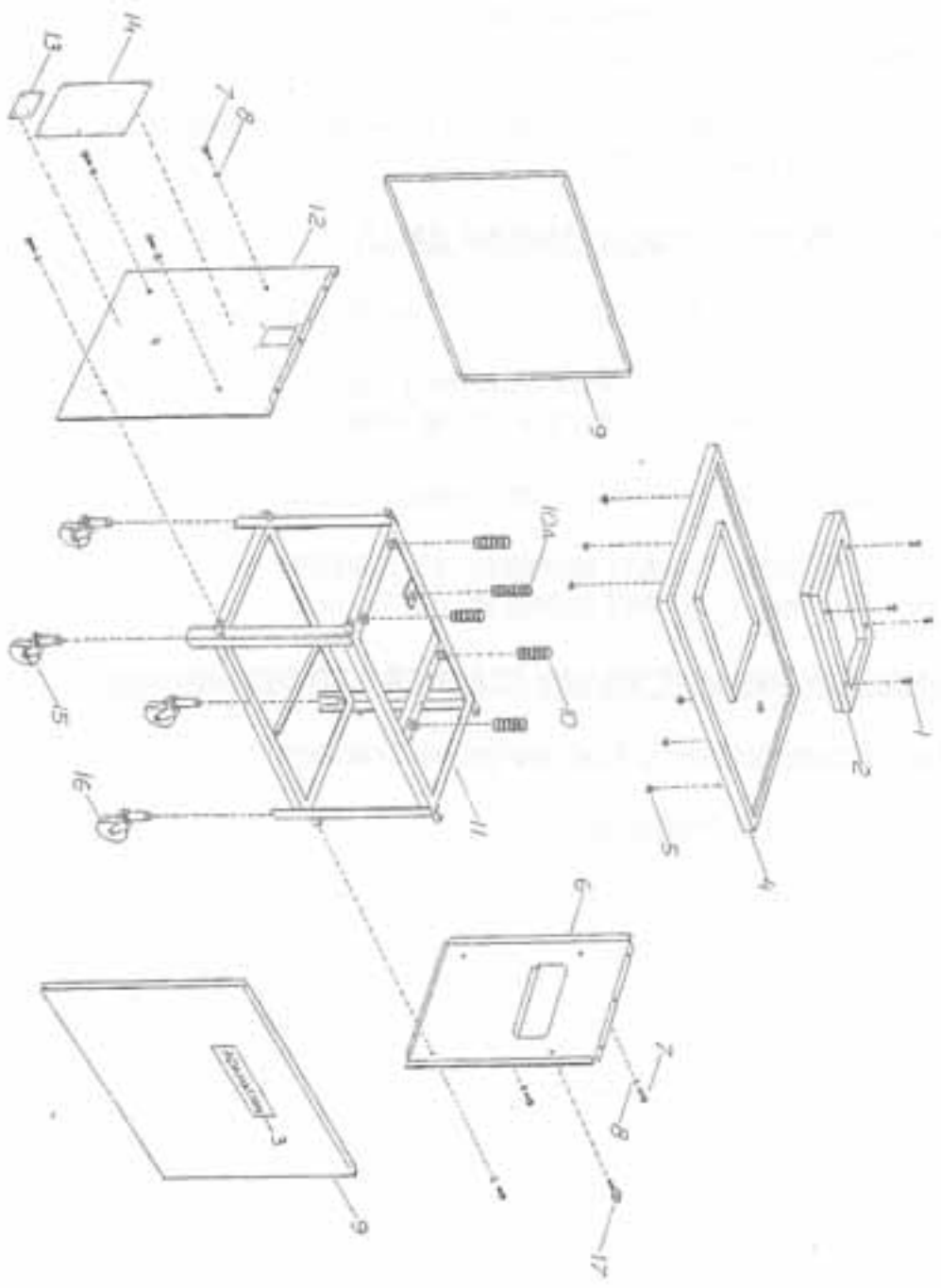

VM-126 FRAME WORK AND CABINET ASSEMBLY
FIGURE 2

PARTS LIST----VM126 FRAME WORK AND CABINET ASSEMBLY (FIGURE #2)

INDEX NO.	PART NUMBER	PART DESCRIPTION	QTY PER ASS'Y
1	10-1008-420	SCREW, PAN HEAD, 1/4-20 X 1" LONG	4
2	32-1409-000	BEZEL FRAME ASSEMBLY WITH SKIRT, S/S	1
3	17-0818-900	PLATE, ADAMATION NAME, 3-3/4" X 11-3/4", S/S	2
4	N.P.N.	TABLE TOP ASSEMBLY (REF. DWG#C2M-14-58)	1
5	10-1901-420	FLEXNUT, 1/4-20, S/S	6
6	32-1405-901	PANEL, RESERVOIR END, S/S	1
7	10-1004-420	SCREW, PAN HEAD, 1/4-20 X 1/2" LONG, S/S	8
8	10-1801-420	WASHER, LOCK, 1/4", S/S	8
9	32-1405-903	PANEL, SIDE, S/S	2
10	70-7400-050	SPRING, SC4 X 2 X .250	4
10A	70-7400-053	SPRING DAMPER	1
11	N.P.N.	FRAME ASSEMBLY (REF. DWG#C2M-14-118)	1
12	32-1405-902	PANEL, SWITCH END, S/S	1
13	17-0810-000	PLATE, SERIAL NUMBER	1
14	17-0613-400	PLATE, OPERATING INSTRUCTIONS	1
15	70-0851-001	CASTER, WITH BRAKE	2
16	70-0851-501	CASTER, WITHOUT BRAKE	2
17	11-1404-400	HANGER, DRAIN HOSE, 1/4-20, S/S	1

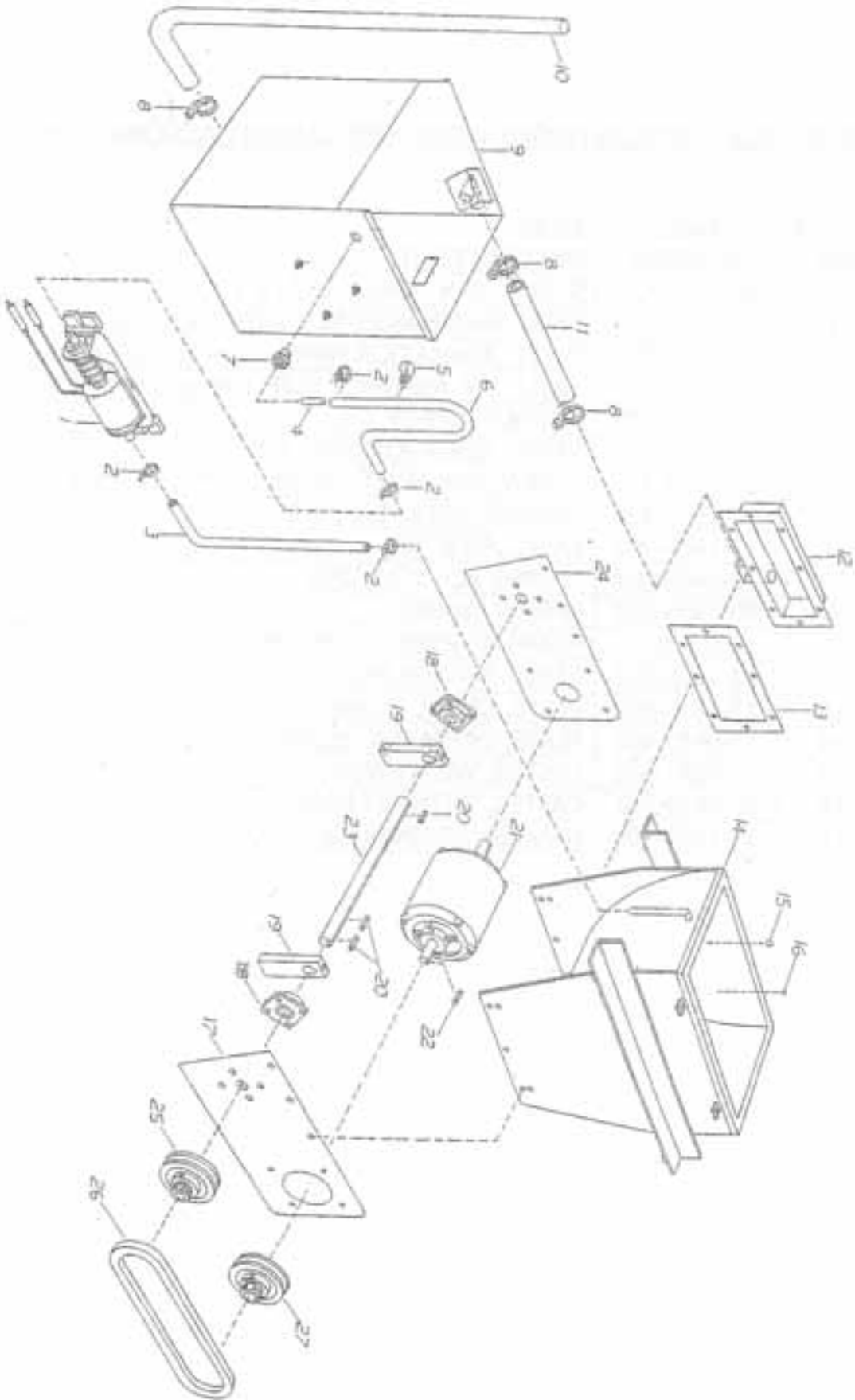

VM-126 BARREL, DRIVE, AND PUMP ASSEMBLY
FIGURE 3

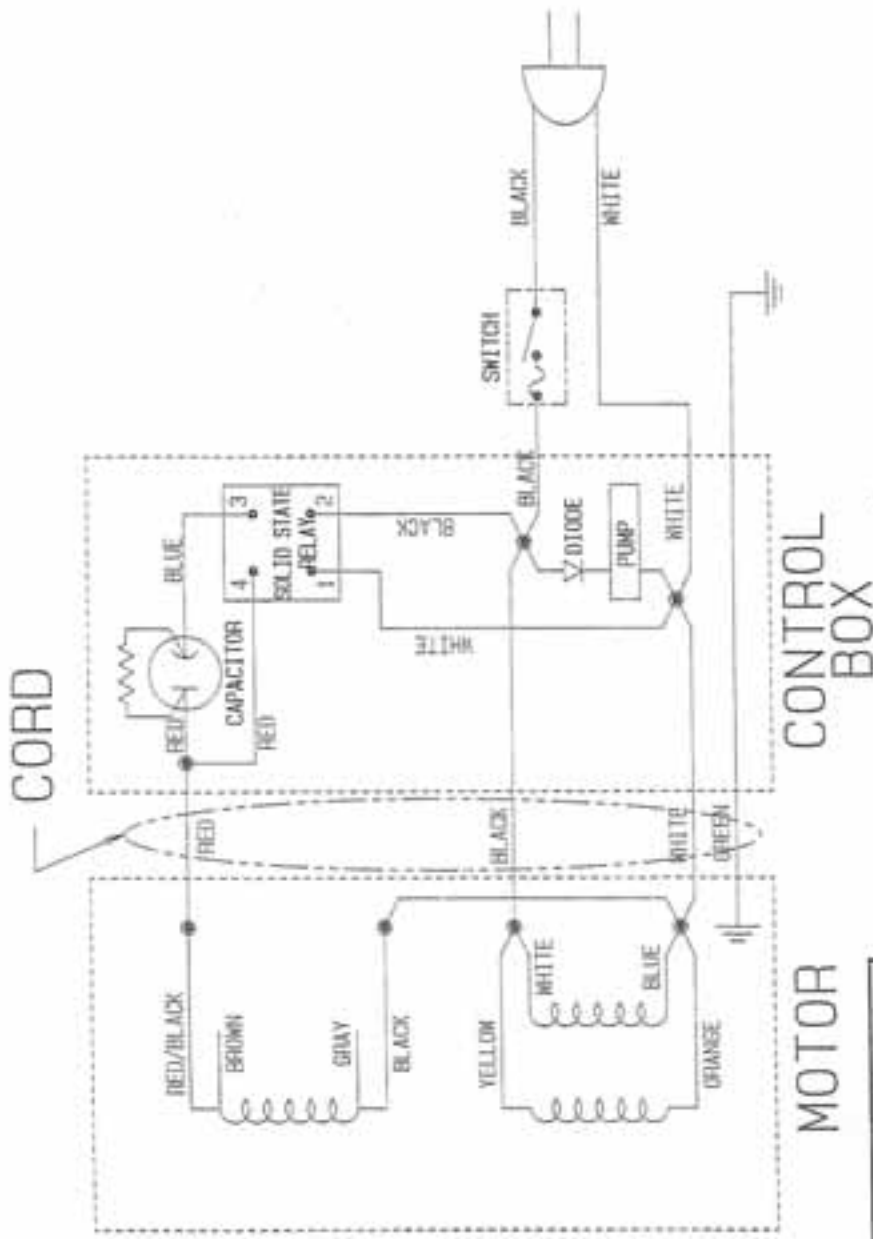

Adamation

37 ADAM STREET, WESTON, MASSACHUSETTS 02457
Telephone: 617-234-3500
Industrial service and engineering of fluid service systems and equipment.

**WIRING DIAGRAM FOR 115V
VM 126 MOTOR & PUMP**

<small>DR: JG</small>	<small>SCALE: NONE</small>	<small>REV: A2E-2-49</small>
<small>DATE: 02-03-84</small>	<small>DR: JG</small>	

PARTS LIST----VM126 BARREL, DRIVE, AND PUMP ASSEMBLY (FIGURE #3)

INDEX NO.	PART NUMBER	PART DESCRIPTION	QTY PER ASS'Y
1	55-6300-500	PUMP, WITH DIODE, 115V OSCILLATING, 60 HZ	1
	55-6300-501	PUMP, W/ DIODE, 230V OSCILLATING, 50/60 HZ	1
2	55-2831-003	TIE, RAP, LARGE	4
3	65-7112-002	TUBING, 1/2" OD X 1/4" ID, GUM	32"
4	65-6212-620	TUBING, 1/4" OD X 1/8" ID, PLASTIC, WHITE	3"
5	70-1000-531	CLAMP, HOSE, PLASTIC	1
6	65-7112-002	TUBING, 1/2" OD X 1/4" ID, GUM	22"
7	70-0715-601	BUSHING	1
8	70-1000-527	CLAMP, HOSE, #16, 13/16" D. TO 1-1/2" D., S/S	3
9	32-1406-000	TANK ASSEMBLY, S/S	1
10	65-6212-863	HOSE, 1-1/4" OD X 1" ID, TYGON	38"
11	65-7112-003	HOSE, 1-1/4" OD X 1" ID, GUM	12.5"
12	32-1405-700	DRAIN BOX, S/S	1
13	19-4201-600	GASKET, DRAIN BOX	1
14	32-1406-100	DRUM, BURNISHING BARREL	1
15	65-7300-010	BURNISHING BALLS, 1/4" DIAMETER, PER 25 lbs.	75 lbs.
16	65-7300-001	BURNISHING BALLS, 3/16" DIAMETER, PER 25 lbs.	75 lbs.
17	41-1414-901	MOUNTING PLATE, MTR-BACK END (SMALL HOLE)	1
18	70-0455-060	BEARING, FLANGE	2
19	11-1406-702	COUNTERWEIGHT, 1" BORE	2
20	19-2100-108	KEY, 1/4" X 1/4" X 2-1/2" LONG	3
21	99-4800-051	MOTOR, 1 HP, 115/230V, SINGLE PH, 50/60 HZ	1
22	19-2100-204	KEY, 3/16" X 3/16" X 1-1/2" LONG	1
23	21-1414-400	SHAFT, 1"	1
24	41-1414-902	MOUNTING PLATE, MTR-PULLEY END (BIG HOLE)	1
25	70-6303-004	PULLEY, 4" OD X 1" BORE, ADJ. PITCH (60 HZ)	1
	70-6300-093	PULLEY, 3" OD X 1" BORE, ADJ. PITCH (50 HZ)	1
26	70-0500-527	BELT, "V", 27" (60 HZ)	1
	70-0500-525	BELT, "V", 25" (50 HZ EXPORT ONLY)	1
27	70-6303-003	PULLEY, 4" OD X 7/8" BORE, ADJUSTABLE PITCH	1

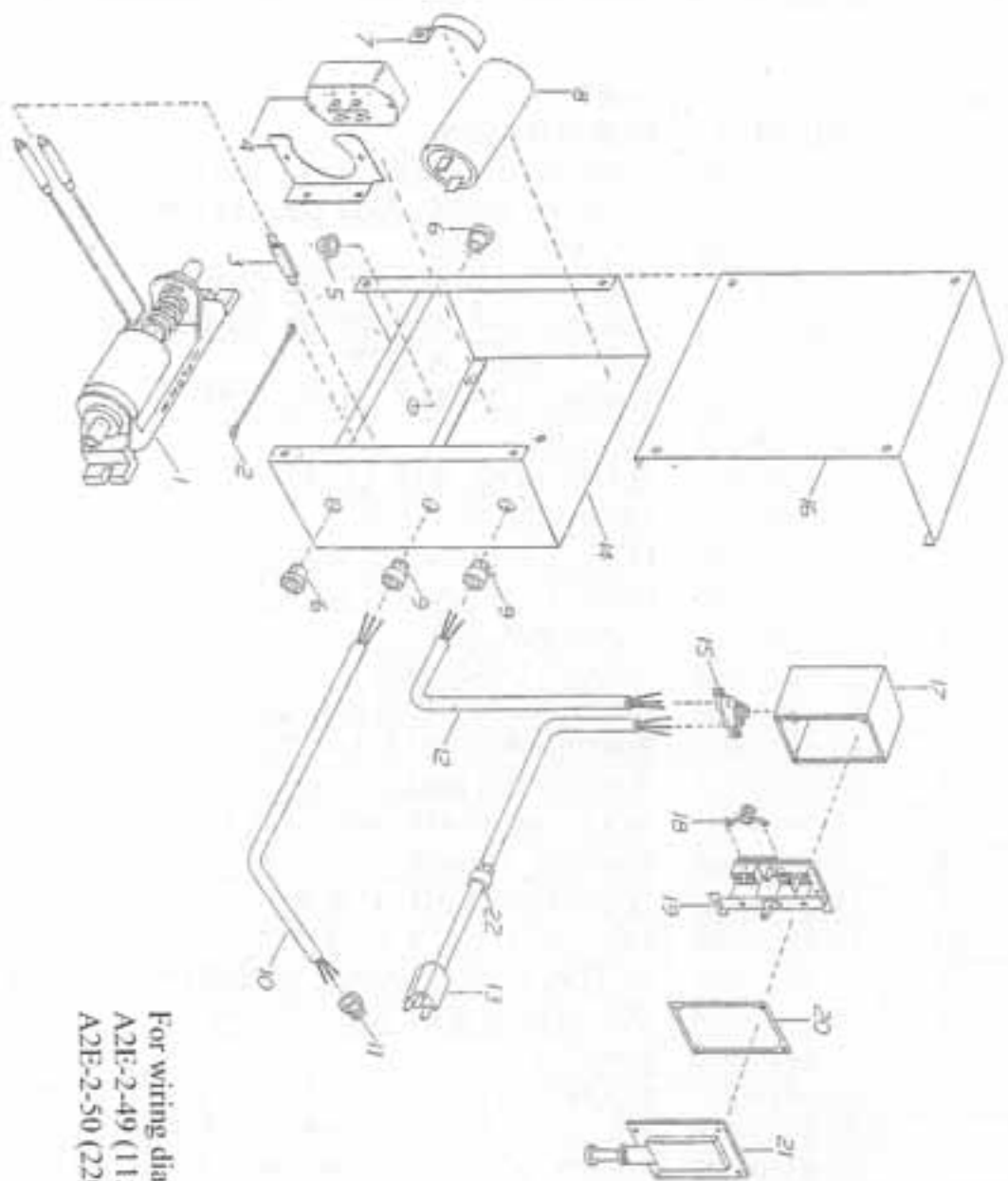

VM-126 ELECTRICAL ASSEMBLY
FIGURE 4

For wiring diagrams, refer to:
A2E-2-49 (115V)
A2E-2-50 (220V)

PARTS LIST----VM126 ELECTRICAL ASSEMBLY (FIGURE #4)

INDEX NO.	PART NUMBER	PART DESCRIPTION	QTY PER ASS'Y
1	55-6300-500	PUMP, WITH DIODE, 115V OSCILLATING, 60 HZ	1
	55-6300-501	PUMP, W/ DIODE, 230V OSCILLATING, 50/60 HZ	1
2	15-0700-700	WIRE, PUMP GROUND	1
3	55-6840-001	DIODE, 115/230V	1
4	55-6850-676	RELAY, SOLID ST., STERN #CV-25-165, W/ BRCKT	1
5	70-2550-054	GROMMET, RUBBER, KEYSTONE #749	1
6	70-0715-601	BUSHING, HEYCO #SB87511	2
7	11-0918-800	CAPACITOR CLIP	1
8	55-0850-010	CAPACITOR, 115V, 455MFD	1
9	55-2000-022	CONNECTOR, HEYCO #1260	2
10	65-9204-144	CORD	49"
11	55-2000-004	CONNECTOR, 14/4 STRAIN RELIEF	1
12	65-9204-144	CORD	48"
13	55-1060-304	POWER CORD	1
14	31-0527-700	PUMP & ELECT. CONTROLS ENCLOSURE W/ CVR	1
15	55-2000-006	CONNECTOR, CABLE, DUPLEX	1
16	---	ENCLOSURE COVER, INCLUDED WITH INDEX #14	--
17	55-0600-046	BOX, ELECTRICAL, 2" X 4"	1
18	55-2855-139	HEATER, OVERLOAD, AB #P39 (115V)	1
	55-2855-132	HEATER, OVERLOAD, AB #P32 (220V)	1
19	55-7381-001	SWITCH, STARTER	1
20	---	GASKET, INCLUDED WITH INDEX #21	--
21	55-1100-011	COVER, PUSH/PULL TYPE, WITH GASKET	1
22	55-2000-021	CONNECTOR, HEYCO #SR-7W-2	1

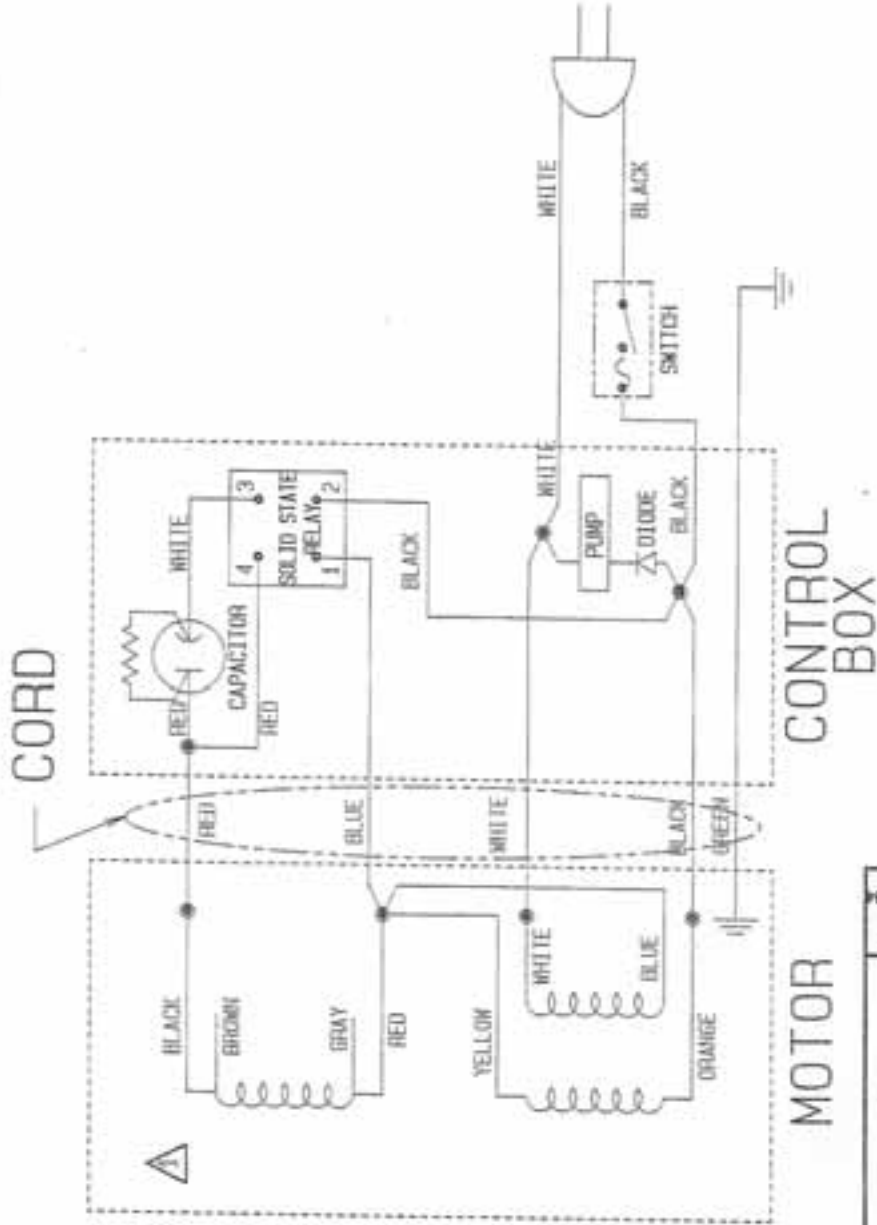

Adamation

67 Adams Street, Boston, Massachusetts 02108
Telephone: 617-749-1000
Specialists in design and engineering of fluid service systems and equipment.

**WIRING DIAGRAM FOR 220V
VM 126 MOTOR & PUMP**

<small>DR: JET 4, 1973A</small>	<small>Scale: NONE</small>	<small>Rev: A2E-2-50</small>
<small>DATE: 12 OCT 88</small>	<small>BY: JET</small>	

REVERSE THE RED & BLACK MOTOR
WIRE SOURCE, EGM 0028 WMT 8/23/94