



The Inventors of the Carousel Dishmachine
Adamation is the originator of the carousel concept, and has been the industry leader for nearly 50 years. The space utilization, ergonomics, design flexibility and labor savings are unmatched by any other style of machine.

All Adamation Carousel Dishmachines are custom built-to-order and are available in a wide variety of shapes and sizes to meet the unique needs of any food service operation. The specifications listed here should be used as guidelines only, as the numerous options could not be covered in detail. Please contact your Adamation representative to consult on the exact machine for your requirements.

OPTIONAL EQUIPMENT

- Drain Board with extra Hommel Pot Basket
Allows for switching of baskets while machine is in operation.
- Side Spraying Manifolds
Improves washing performance for wares such as thermal trays.
- Booster Heaters*
Available in electric, steam or gas models.
- Blower / Dryer
Heated, forced-air rapid drying system.
- Hose Station with Check Valves*
Includes integrated H/C faucet for convenient clean up.
- Hand Wash Station with Soap Bracket
Mounted between loading and unloading areas of machine, permits convenient washing of hands without wasted motion.

*See spec sheets on individual options for complete details

AC-2

Double Tank Continuous Conveyor Dishmachine
Rated capacity of 500 20" x 20" racks per hours at 14.3 ft. per minute conveyor speed (approx. 9200 pcs. per hour).

- AC-2E - Electric heat
- AC-2S - Steam heat

STANDARD FEATURES

- Heavy-duty Stainless Steel construction
12 ga. stainless steel tables; 16 ga. hoods and cabinets.
- 25" Wash Tunnel
Easily handles full-size sheet pans and stock pots up to 80 qt.
- Powerful Recirculating Pumps
3 hp main wash pump recirculating 320 gpm; 1 1/2 hp power prewash recirculating 75 gpm, 3/4 hp pre-final rinse pump; 3/4 hp transfer pump to pulper trough or disposer.
- Exclusive Disengagable Worm-gear Drive
Allows for flat table construction with no belts or chains. Hinged system easily disengages to allow carousel to be advanced or reversed by hand.
- Exclusive Dolly System with Stainless Wheels
Nearly friction-free design glides smoothly above table surface.
- Water Saving Pre-Final Rinse
Re-uses 180° final rinse water to increase rinsing efficiency.
- Single Point Connections
Single point connections for each utility.
- Insulated Wash Cabinets and Doors
- Slanted Overhead Rack Storage for 20" Racks
- Two Knee-operated Start/Stop Switches

WASTE HANDLING OPTIONS

- Food Waste Pulper
Reduces waste bulk by over 80% and eliminates most water weight while reducing ecological load on sewage system. A variety of food soil troughs are available.
- Garbage Disposer
Supplied by Adamation or use existing system. A variety of food soil troughs are available.
- Spiral Trough
Open worm gear moves bulk garbage from scrapping area to garbage can at end of line. Economical alternative when disposer or pulper are not applicable.



ADAMATION WAREWASHER MODEL ACS-2

NOTES: 1) ALL DIMENSIONS SHOWN ARE
MINIMUM LENGTHS
2) FOR PULPER DIMENSIONS, PLEASE
REFER TO PULPER PAGES

SLIM JIM CONFIGURATION
WITHOUT SUPER BLOWER

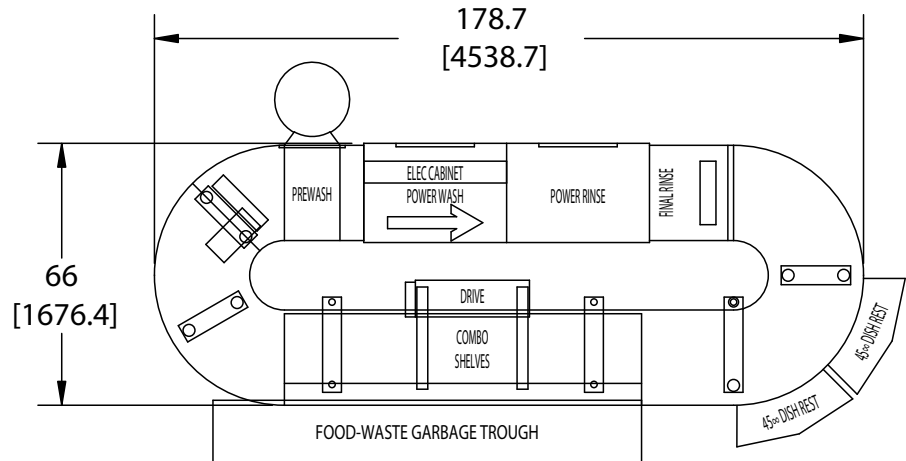

STANDARD CONFIGURATION
WITHOUT SUPER BLOWER

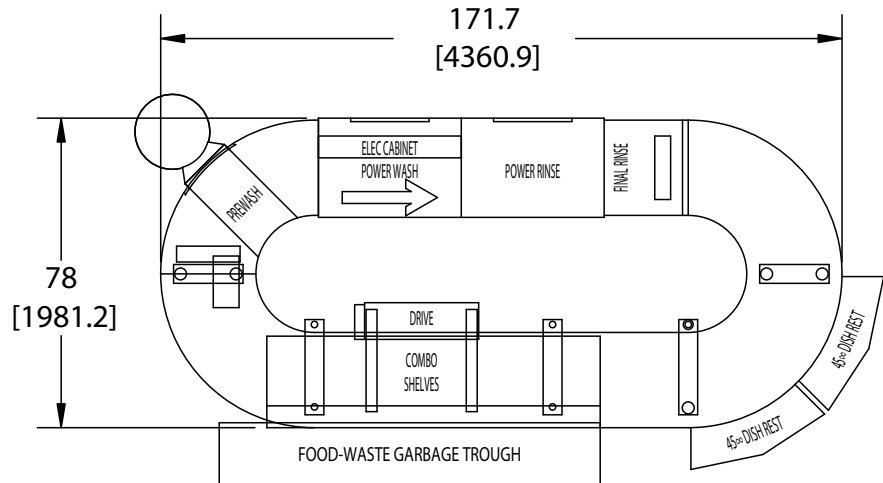

Specifications

Rated Capacity	Tank Capacity	Motors (HP / Qty.)	Pump Capacity	Rinse Water Usage (@20psi)	Exhaust (CFM)
500 racks/hr	Prewash - 5 gal.	Prewash - 1 hp x 1	Prewash - 50 gpm	258 gal./hr.	Load end - 400
14.3 ft./min.	Wash/Rinse - 22.5 gal.	Wash/Rinse - 3hp x 2	Wash/Rinse - 300 gpm	0.51 gal./rack	Unload end - 700
9200 pcs./hr.	Prerinse - 3 gal.	Prerinse - 3.4 hp x 1	Prerinse - 12.6 gpm	-	-

Electrical Requirements

Current (V/Ph/Cyc)	Electric Heat	Steam Heat
240/3/60	137 amps	26.5 amps
480/3/60	69 amps	13.5 amps